

iHn High Voltage Interface

Hardware Reference



Updated 2024-02-05

© 2016-2024 Tucker-Davis Technologies, Inc. (TDT). All rights reserved.

Tucker-Davis Technologies
11930 Research Circle
Alachua, FL 32615 USA
Phone: +1.386.462.9622
Fax: +1.386.462.5365

Notices

The information contained in this document is provided "as is," and is subject to being changed, without notice. TDT shall not be liable for errors or damages in connection with the furnishing, use, or performance of this document or of any information contained herein.

The latest versions of TDT documents are always online at <https://www.tdt.com/docs/>

Table of Contents

iHn High Voltage Interface

Manifolds	5
iHm Manifold	5
iHm Manifold Molex Pinout	5
iH8-RJ25PLA/B Manifold	6
Typical Configurations	6
iH8-RJ25PLA/B Manifold Pinout	7
iH8-RJ25A/B Manifold	7
Typical Configurations	8
iH8-RJ25A/B Manifold Pinout	8
iHMSG	9
DB15 Pinout	9

iHn High Voltage Interface

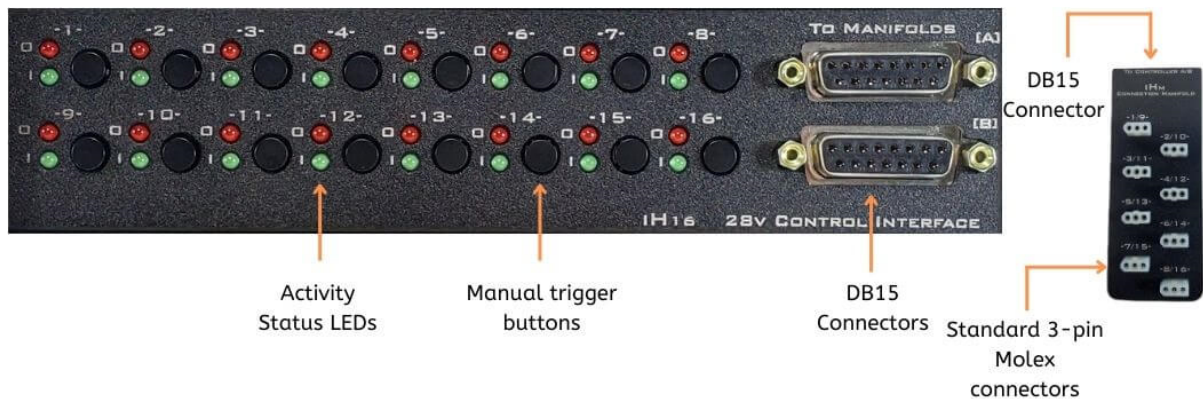

The iH16 and iH8 modules feature 16 or eight bidirectional interface ports to directly control high-voltage (e.g. 28 V signal) cage elements including Med Associates, Lafayette, and Coulbourn. The iH8 and iH16 modules connect to an iHm, iH8-RJ25PLA/B, or iH8-RJ25A/B manifold via a DB15 cable. The manifold can be placed closer to the behavioral apparatus.

- Each interface port is configurable in Synapse as either inputs or outputs
- Manual trigger buttons on the front panel are used for testing / debugging connected behavioral components
- Status lights make it easy to monitor component activity during sessions

The 'O' LED lights when the port is driven by Synapse, and the 'I' LED lights when the port is driven by Synapse, by an external device, or by the manual button press.

An output port can source up to 1 A maximum. The maximum total output per iHn module is 1 A. The maximum total output per iCon is 3 A.

A previous 10 channel model (iH10) has Molex connectors directly on the face of the device.



For information on software control of the iHn modules, see the [Synapse Manual](#).

Manifolds

The iHn comes with one or two manifolds, which interface with cage elements closer to the subject. They connect to the iHn via provided DB15 cables. There are two types of manifolds: the **iHm Manifold** has eight 3-pin Molex connectors and the **iH8-RJ25A/B Manifolds** and **iH8-RJ25PLA/B Manifolds** have eight 6-pin RJ25 connectors.

iHm Manifold

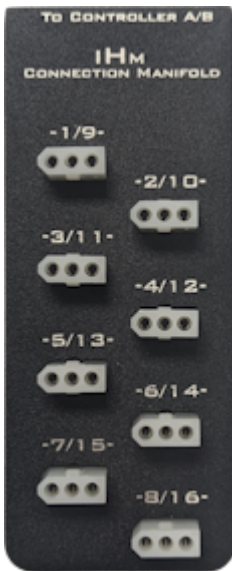

The iHm uses 1.57 mm diameter standard Molex pin and socket connectors.

iHm Manifold Molex Pinout

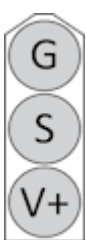

Pin	Name	Description
G	Ground	
S	Signal	Input or output signal
V+	+28 V	+28 V up to 1 A, 3 A max per iCon

As an **Input**, the Signal line floats to +28 V. Short the Signal line to ground to trigger it. As an **Output**, the Signal line floats by default and is shorted to 0 V when triggered.

iH8-RJ25PLA/B Manifold

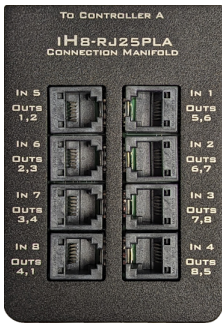

The iH8-RJ25PLA/B manifolds feature 8 telephone-style 6-pin RJ25 ports to provide direct control of high-voltage (e.g. 28V signal) cage elements from Panlab.

- There are a total of 8 inputs and outputs combined per manifold
- The ports are configurable in Synapse as either inputs or outputs
- Each port has one input and two outputs

The numbers on the faceplate indicate which input channels and output channels are available on that connector. The outputs that are shared between ports are physically shorted together inside the iH8-RJ25. For example, Out 2 on the iH8-RJ25PLA is available on the first two ports and is controlled by the same signal from Synapse.

Similarly, inputs and outputs of the same number are shorted internally. For example, Out1 and In1 share the same signal from the iHn and you can't use both at the same time.

The iH8-RJ25PLA and iH8-RJ25PLB models are electrically identical, but have different channel numbering on the faceplate to match the A and B inputs on the iH16 module.

Typical Configurations

Device Type	Configuration
Up to 8 input-only devices	Connect each device to an RJ25 connector. Configure all 8 as inputs in Synapse
Up to 8 output-only devices	Connect each device to an RJ25 connector. Configure all 8 as outputs in Synapse
4 input-only and 4 output-only devices	Connect the inputs to In1, In3, In5, In7. Connect the outputs to Out2, Out4, Out6, Out8
4 devices with 1 input and 1 output each	Connect to In1 (Out5), In2 (Out6), In3 (Out7), In4 (Out8)

iH8-RJ25PLA/B Manifold Pinout

Pinout looking into the connector

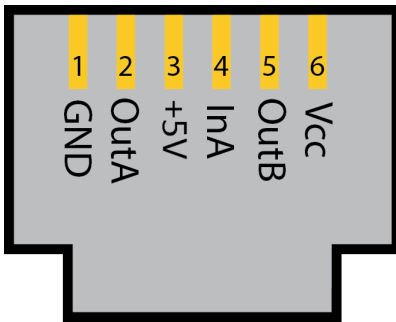

Pin	Name	Description
1	GND	Ground
2	OutA	Output Signal A
3	+5V	
4	InA	Output Signal
5	OutB	Output Signal B
6	V+	+28 V up to 1 A, 3 A max per iCon

iH8-RJ25A/B Manifold



The iH8-RJ25A/B manifolds feature 8 telephone-style 6-pin RJ25 ports to provide direct control of high-voltage (e.g. 28V signal) cage elements from Coulbourn.

- There are a total of 8 inputs and outputs combined per manifold
- The ports are configurable in Synapse as either inputs or outputs
- Each port has one input and up to three outputs

The numbers on the faceplate indicate which input channels and output channels are available on that connector. The outputs that are shared between ports are physically shorted together inside the iH8-RJ25. For example, Out 6 on the iH8-RJ25A is available on the first two ports and is controlled by the same signal from Synapse.

Similarly, inputs and outputs of the same number are shorted internally. For example, Out1 and In1 share the same signal from the iHn and you can't use both at the same time.

The iH8-RJ25A and iH8-RJ25B models are electrically identical, but have different channel numbering on the faceplate to match the A and B inputs on the iH16 module.

Typical Configurations

Device Type	Configuration
Up to 8 input-only devices	Connect each device to an RJ25 connector. Configure all 8 as inputs in Synapse
Up to 8 output-only devices	Connect each device to an RJ25 connector. Configure all 8 as outputs in Synapse
4 input-only and 4 output-only devices	Connect the inputs to In1, In3, In5, In7. Connect the outputs to Out2, Out4, Out6, Out8
4 devices with 1 input and 1 output each	Connect to In1 (Out5), In2 (Out6), In3 (Out7), In4 (Out8)

iH8-RJ25A/B Manifold Pinout

Pinout looking into the connector

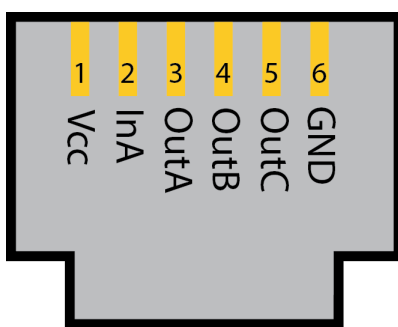

Pin	Name	Description
1	GND	Ground
2	OutA	Output Signal A
3	OutB*	Output Signal B*
4	OutC**	Output Signal C**
5	InA	Input Signal
6	V+	+28 V up to 1 A, 3 A max per iCon

Note

* Not available on connector 4 or 8

** Not available on connector 3, 4, 7, or 8

iHMSG

The iHMSG cable interfaces a third-party behavioral control box with the iHm manifolds. It has a DB25 on one end to connect to the third-party system, and two DB15s on the other end to connect to iHm manifolds. The DB15s are labeled "A" and "B" for the upper and lower bits.

DB15 Pinout

If you are not using a TDT manifold and are instead connecting directly to the iH8/iH16 DB15 port, here is the pinout:

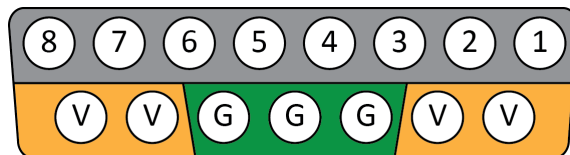

iHn A pinout, looking into the connector

Pin	Name	Description	Pin	Name	Description
1	I/O 1	Input/Output 1	9	Vcc	+28 V up to 1 A, 3 A max per iCon
2	I/O 2	Input/Output 2	10	Vcc	
3	I/O 3	Input/Output 3	11	Gnd	Ground
4	I/O 4	Input/Output 4	12	Gnd	
5	I/O 5	Input/Output 5	13	Gnd	
6	I/O 6	Input/Output 6	14	Vcc	
7	I/O 7	Input/Output 7	15	Vcc	
8	I/O 8	Input/Output 8			

All Ground pins are shorted together. All Vcc pins are shorted together.

The B connector on the iH16 is identically wired, except Pins 1-8 are I/O 9-16.