

ZIF-Clip® ZCD Digital Headstages

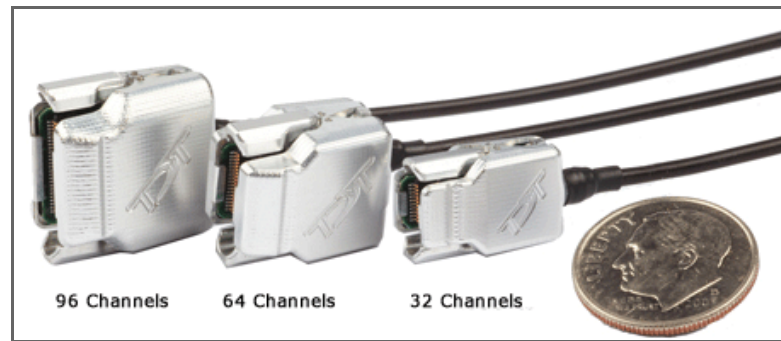

ZCD Digital Headstages

ZIF-Clip® ZCD Overview

ZIF-Clip® digital headstages use an Intan amplifier chip to digitize physiological recordings directly inside the clip. Digitized signals are routed to a PZ4 headstage manifold through a single cable for transfer to an RZ base station.

The ZIF-Clip® headstage (Patent No. 7540752) features an innovative, hinged headstage design that ensures quick, easy headstage connection with almost no insertion force applied to the subject. ZIF-Clip® headstage contacts seat inside the probe array and snap in place, firmly locking the headstage and probe with very little applied pressure. These self-aligning headstages provide long lasting low insertion performance for a variety of channel number and electrode configurations. An aluminum finish provides increased durability.

The headstages are recommended for use with probe impedance that range from 20 Kohm to 2 Mohm. By default, ground and reference are separate on all ZIF-Clip® headstages yielding a referential configuration. Reference and ground may be tied together on the headstage adapter or ZIF-Clip® microwire array for single-ended configurations.

Part Numbers:

ZCD32 - 32-channel Digital ZIF-Clip® headstage

ZCD64 - 64-channel Digital ZIF-Clip® headstage

ZCD96 - 96-channel Digital ZIF-Clip® headstage

Adapter and Probe Connection



The headstage has sensitive electronics. Always ground yourself before handling.

ZIF-Clip® headstages are designed to automatically position the high density connectors on the headstage and probe (or adapter).

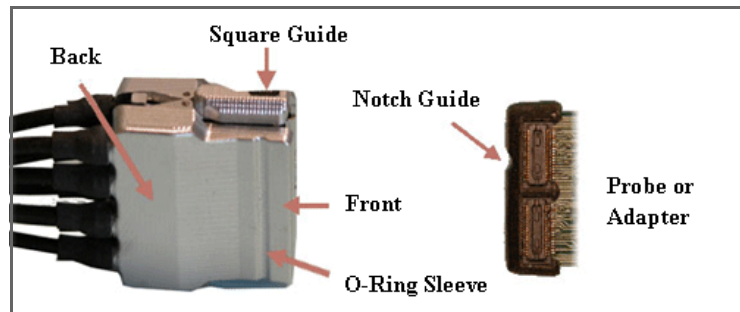

ZIF-Clip® Connection (Analog Headstage Pictured)

Connect probes and adapters to the headstage as described below.



Firmly press and hold the **back** to open the headstage.

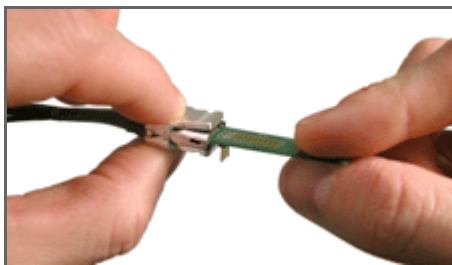

Align the **notch guide** of connector to the **black square guide** of the fully opened headstage then move headstage into position.



WARNING! The ZIF-Clip® headstage must be held in the fully open position while being slid into position. The headstage should only be closed when fully engaged. Sliding the headstage into position while applying pressure to the tip will **permanently damage** the ZIF-Clip® headstage and micro connectors.

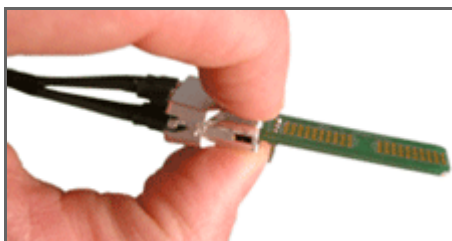

Press the **front** of the headstage together as shown to lock the connector in place. You should hear an audible click when the locking mechanism is engaged.

ZIF-Clip® Headstage O-Rings

All ZIF-Clip® headstages are shipped with two o-rings for additional connection security. Gently slip the o-ring onto the headstage sleeve and then roll the o-ring towards the back of the headstage. Connect the probe or adapter to the headstage as described above. Once the connection is secure, roll the o-ring forward until it settles into the sleeve on the front of the headstage.



O-Ring Use and Positioning

ZIF-Clip® Digital Headstage Manifold Connection

The ZIF-Clip® digital headstage has one MiniDB26 connector that transmits all channels for that headstage. Up to four ZIF-Clip® digital headstages can be connected to a PZ4 Digital Headstage Manifold. The PZ4 will automatically detect the number of channels in each headstage. All channels will be concatenated together, starting with connector “-A-”, to create the output signal to the RZ base station. The total channel count of all connected headstages cannot exceed the maximum channel count for the PZ4. See “PZ4 Digital Headstage Manifold” on page 6-25, for more information.

ZIF-Clip® ZCD Digital Headstage Technical Specifications

Input referred noise	4 μV_{RMS} bandwidth 300-3000 Hz 7 μV_{RMS} bandwidth 30-8000 Hz
Headstage Gain	Unity (1x)
Input Impedance	1300 Mohm, 10Hz 13 Mohm, 1kHz TDT recommends using less than 2 Mohm electrodes
A/D	Up to 96 channels, 16-bit PCM
A/D Sample Rate	Up to 24414.0625 Hz
Maximum Voltage In	+/- 5 mV
Frequency Response	0.3 Hz to 7.5 kHz (3dB)

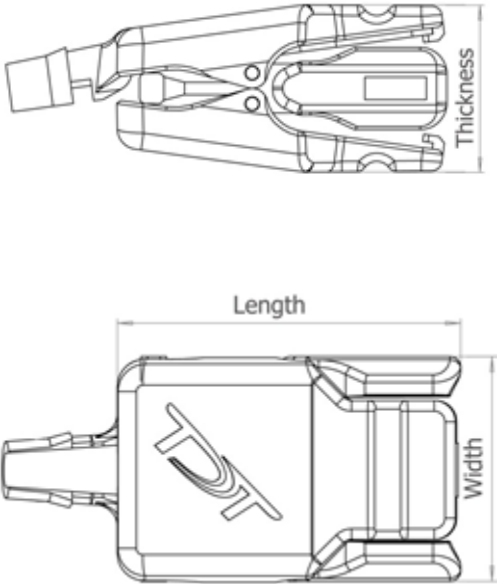
Anti-Aliasing Filter	3rd order low-pass (-18 dB per octave)				
Distortion (typical)	< 1%				
Channel Cross Talk	-75 dB				
Dimensions (Approx.)					
					
Headstage	Length Open	Length Closed	Width	Thickness Open	Thickness Closed
ZCD32	16.107 mm	16.050 mm	10.500 mm	8.137 mm	7.400 mm
ZCD64	16.446 mm	16.497 mm	15.500 mm	12.760 mm	10.400 mm
ZCD96	17.469 mm	17.562 mm	19.000 mm	12.577 mm	10.499 mm

Important! When using multiple headstages, ensure that a single ground is used for all headstages. This will avoid unnecessary noise contamination in recordings. See “Headstage Connection Guide” on page 6-99, for more information.

ZIF-Clip® Headstage Pinouts

If you are interested in using a third party electrode see “ZIF-Clip® Headstage Adapters” on page 12-9. If there is no adapter offered for the desired electrode, the following diagrams show the headstage pinouts (channel connections to the amplifier) and board dimensions for connectors to match ZIF-Clip® headstages. A black square guide is used to align the headstage to ZIF-Clip® compatible connectors and can be used in the diagrams below to orient “left” and “right” sides of the headstage shell. Channel numbers are relative to the manifold connection to which they are connected.

16- and 32-Channel Headstage Pinouts

Images are not to scale. Pinouts are looking through the headstage shell (or into a matching board connector). All board dimensions are in millimeters and are identical for both sides, board thickness is 0.75 mm, and connectors are centered as shown.

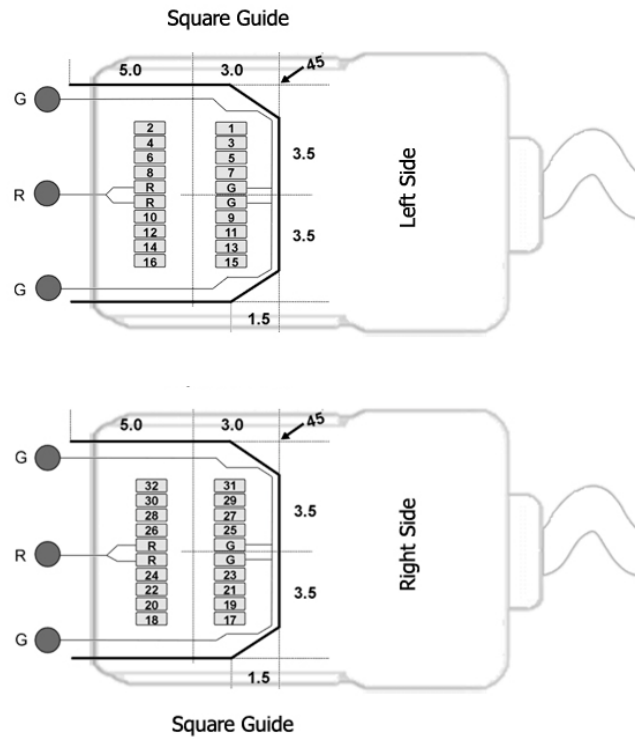

G Common/Ground Connection

R Reference Connection

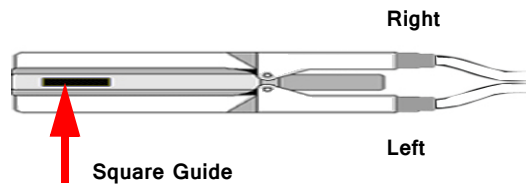

Note: The 16-channel headstage does not have any pins connected on the right side of the headstage; the Hirose connector is there for mechanical support. See Hirose specification for recommended footprint.

Hirose Connectors:

ZCD16 - DF30FC-20DS-0.4V x 1

ZCD32 - DF30FC-20DS-0.4V x 2

64-Channel Headstage Pinouts

Images are not to scale. Pinouts are looking through the headstage shell (or into a matching board connector). All board dimensions are in millimeters and are identical for both sides, board thickness is 0.75 mm, and connectors are centered as shown.

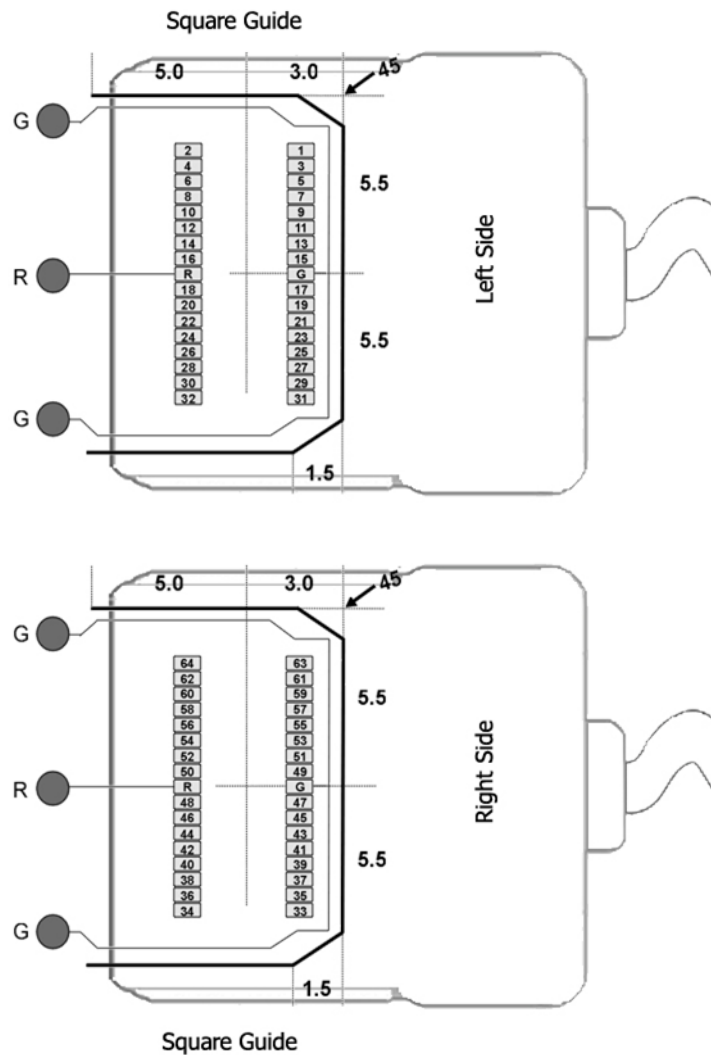

G Common/Ground Connection
 R Reference Connection

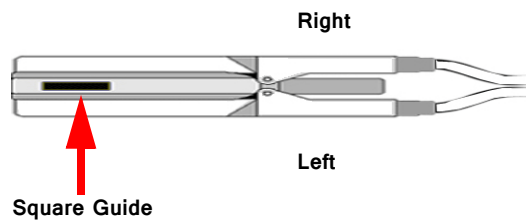

See Hirose specification for recommended footprint.

Hirose Connectors:

ZCD64 - DF30FC-34DS-0.4V x 2

96-Channel Headstage Pinouts

Images are not to scale. Pinouts are looking through the headstage shell (or into a matching board connector). All board dimensions are in millimeters and are identical for both sides, board thickness is 0.75 mm, and connectors are centered as shown.

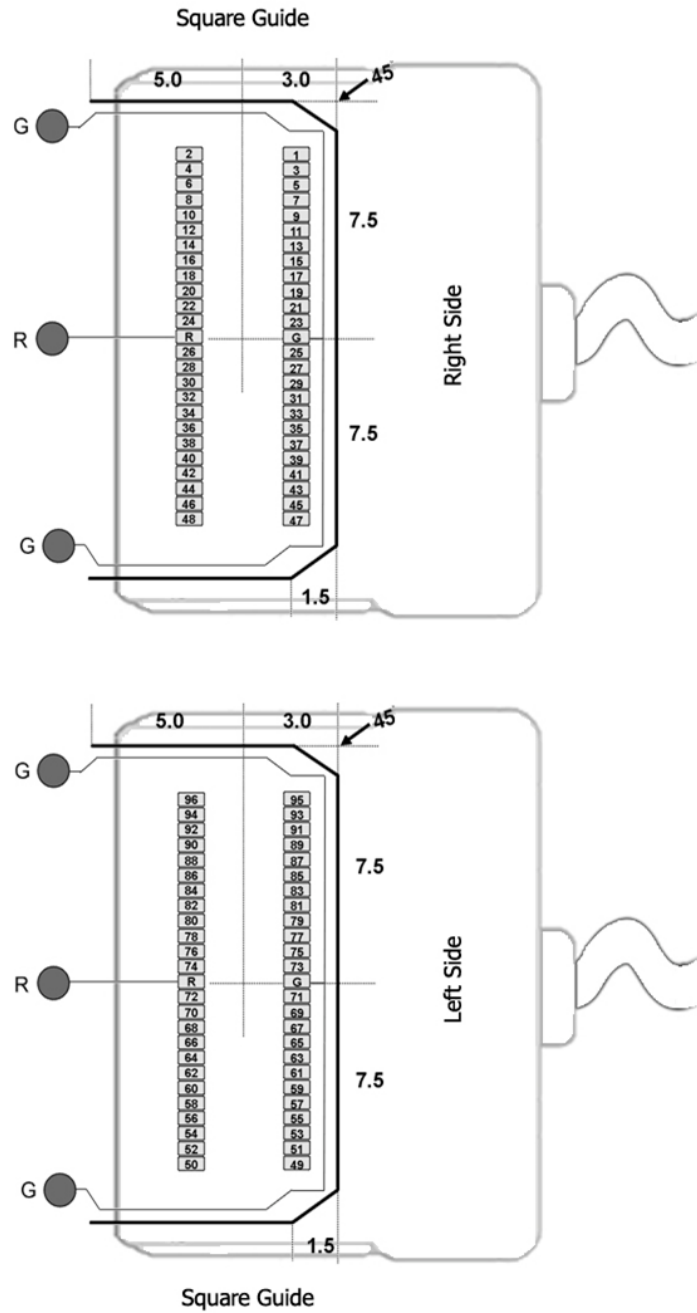

G Common/Ground Connection
 R Reference Connection

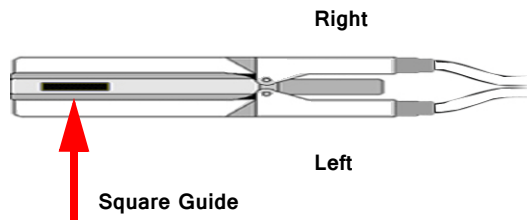

See Hirose specification for recommended footprint.

Hirose Connectors:

ZCD96 - DF30FC-50DS-0.4V x 2

