

ZIF-Clip® Headstages to Mill-Max Probes

ZIF-Clip® headstage adapters are available for use with a variety of electrodes. Standard operation for ZIF-Clip® headstages is shared differential [ground and reference are not tied together]. When using the ZIF-Clip® headstage with an adapter, it can be configured for single-ended operation by tying ground[G] and reference[R] connections together on the adapter. The reverse side of this fast facts provides pinouts for MILL-MAX BASED adapters.

Adapter and Site Remapping. ZIF-Clip® headstage adapters enable the use of third party electrodes; however, they do add another layer of complexity when determining which physical site corresponds to each channel number in the data. Remapping the channel numbers to a desired “map” can simplify the task of interpreting your data.

TDT provides an automated remapping function through Synapse’s Mapper gizmo. Mapper takes into account the pinouts of the electrode as well as those of any adapters to the TDT headstage.

When using the Mapper gizmo, the remap values are obtained by inputting the electrode pinouts in a “Custom” column in the Mapper interface and selecting the appropriate adapter in the second column. The Final Map is displayed at runtime.

For some setups you might also need to include a column in the table for the headstage [when using ZD64 or ZD96, or third party headstages]. The columns must be ordered left to right, beginning with the electrode. As a rule of thumb, you’ll need a column in the map table for each connection, up to the point when only TDT components [adapter, headstage] remain. Most TDT adapters and headstages have one-to-one connections, meaning that when connected, the pinouts represent the preamplifier channels.

Unfortunately, the electrode pinout does not necessarily match the adapter pinout. For example, the ZCA-DIP16 adapter [shown above-right] does not map directly to the NeuroNexus 16-channel electrode. Further, in the existing site map the channel numbers are not assigned in a logical order.

In the figure below, the mapper reorders the physical sites from 1 to 16 in terms of spatial depth. Site 1 in the desired site map, is physically connected to pin 9 on the electrode pinout. On the adapter pinout this channel corresponds to the amplifier channel number 15. Therefore, the Remap value for channel 1 should be the value 15.

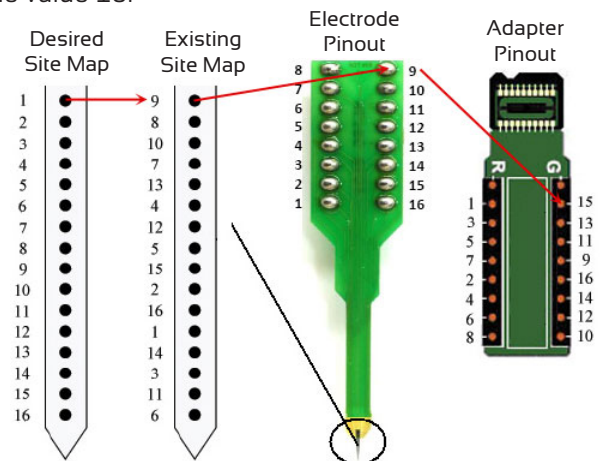

The table below represents the final site remapping for the mapper.

	<input checked="" type="checkbox"/> Active	<input checked="" type="checkbox"/> Active	Final Map	
	<input type="checkbox"/> Mute All	Custom	TDT	
		Custom	ADAPTER	
		Custom	ZCA-DIP16	
1	<input type="checkbox"/>	9	8	15
2	<input type="checkbox"/>	8	6	1
3	<input type="checkbox"/>	10	4	13
4	<input type="checkbox"/>	7	2	3
5	<input type="checkbox"/>	13	7	16
6	<input type="checkbox"/>	4	5	2

In this case, it is easy to visually make this mapping connection, but in more complex adapter configurations, the Mapper can help to organize the information. See the Mapper in the Synapse Manual for more information.

Important! When using multiple headstages, ensure a single ground is used for all headstages. to avoid unnecessary noise contamination in recordings.

Labs not using Synapse, can use RVPdsEx’s MCMAP and DataTable components or input from MATLAB with the use of parameter tags to remap instead.

ZCA-MIL16

Input connector: 18-pin female Mill-Max connector
Connects to: 16-channel Mill-Max based probe
Use with: ZC16, ZD32, ZCD16

Mill-Max Connector Specifications:

Pitch: 0.050" [1.27 mm]
 Row Spacing: 0.050" [1.27 mm]

By default, the inputs are single ended, with reference and ground tied together. To make the inputs differential, sever the jumper trace on the board between reference and ground [shown right] with a sharp knife.

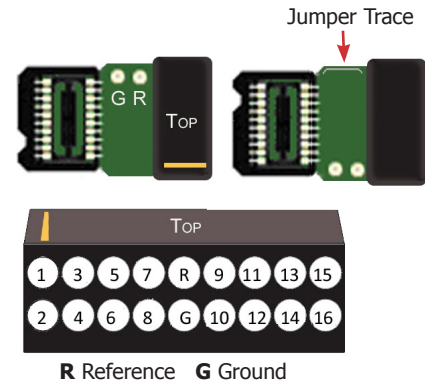

Pinouts are looking into the connector and reflect the preamplifier channels.

ZCA-MIL32

Input connector: 40-pin female Mill-Max connector
Connects to: 32-channel Mill-Max based probe
Use with: ZC32, ZD32, ZCD32

Mill-Max Connector Specifications:

Pitch: 0.050" [1.27 mm]
 Row Spacing: 0.050" [1.27 mm]

By default, the inputs are single ended, with reference and ground tied together. To make the inputs differential, cut the jumper between reference and ground [shown right].

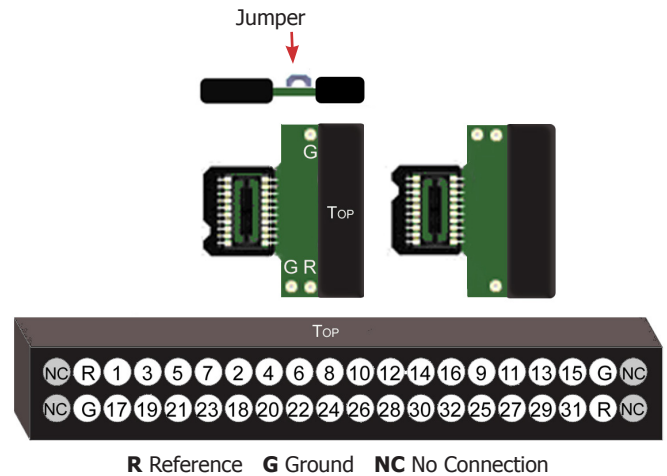

Pinouts are looking into the connector and reflect the preamplifier channels.

ZCA-VD8

Input connectors: [2] 18-socket male Mill-Max connector
 Pitch Pin 1 to Pin 18: 6 mm
Connects to: VersaDrive-8 optical
Use with: ZC32, ZD32, ZCD32

Mill-Max Connector Specifications:

Pitch: 0.050" [1.27 mm]
 Row Spacing: 0.050" [1.27 mm]

The adapter board includes a hole that can be used to secure the adapter to a Versa-8 drive.

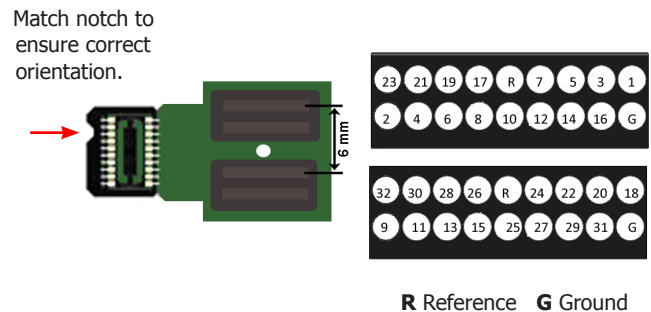

Pinouts are looking through the connector and reflect the preamplifier channels.

See the System 3 Manual for other available parts and information.