



Fast Facts

RX6 MultiFunction Processor



This fast fact sheet provides basic reference information for the RX6 devices. The number of processors [two or five] and status lights depends on the model purchased. See the System 3 Manual for more detailed information.

Analog Input/Output. The RX6 has two channels of 24-bit, sigma-delta D/A and two channels of 24-bit, sigma-delta A/D, each accessible through BNC connectors. Sigma-Delta converters provide superior conversion quality and extended useful bandwidths, at the cost of an inherent fixed group delay. The RX6 **DAC Delay is 43 samples** and the RX6 **ADC Delay is 70 samples**.

Because some RX6 models can acquire analog signals using a preamplifier via an optional fiber optic port, the sigma-delta A/D inputs on all RX6 models are offset and accessed as **ADC channels 128 and 129**.

This device can sample at rates up to 260 kHz for a realizable bandwidth of 120 kHz. For specific information on the actual sampling rates see the table below.

Standard Rate	Actual/Arbitrary Rate [Hz]	Audio ADC	Audio DAC	Optical/AMP Input(Optional)	Digital I/O
6 kHz	6103.52	x	x	x	x
	6975.45	x	x		x
	8138.025	x	x		x
	9765.63	x	x		x
12 kHz	12207.03	x	x	x	x
	13950.89	x	x		x
	16276.04	x	x		x
	19531.25	x	x		x
25 kHz	24414.06	x	x	x	x
	27901.79	x	x		x
	32552.08	x	x		x
	39062.50	x	x		x
50 kHz	48828.13	x	x	x*	x
	55803.57	x	x		x
	65104.17	x	x		x
	78125.00	x	x		x
100 kHz	97656.25	x	x	x*	x
	111607.14	x	x		x
	130208.33	x	x		x
	156250.00	x	x		x
200 kHz	195312.50	x	x		x
	223214.29	x	x		x
	260416.67	x	x		x
	312500.00				x
400 kHz	390625.00				x

[X] = Fully functional [X*] = Sampling limited to 25kHz on PreAmp

Status Lights

Pattern	DSP Status
Steady glow	Device on
Rapid flash	DSP cycle usage > 99%

Front Panel VFD Screen. The front panel VFD can display a variety of status indicators. Cycle through the options using the Mode button to the left of the display. Push and release the button to manually change the display options or push and hold the button for one second then release to automatically cycle through each of the following display options:

- Cyc: cycle usage
- Ovr: processor cycle overages
- Bus%: percentage of internal device's bus capacity used
- I/O%: percentage of data transfer capacity used

The VFD Screen may also report system status such as booting status [Booting DSP] or alert the user when the device's microcode needs to be reprogrammed [Firmware Blank].

Digital I/O. The TTL I/O circuits include 24 bits of programmable digital I/O [16 bits word-addressable and 8-bits bit-addressable]. Digital I/O lines are accessed via the 25-pin connectors on the front panel. By default the Bits lights indicate the logic level [light when high] for the eight bit-addressable digital I/O lines. See the *System 3 Manual* for more information.

DB25 Connector Pinouts

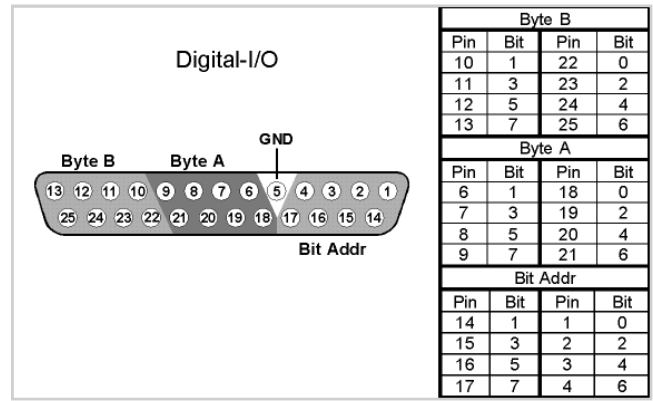

Using the PP24 for I/O

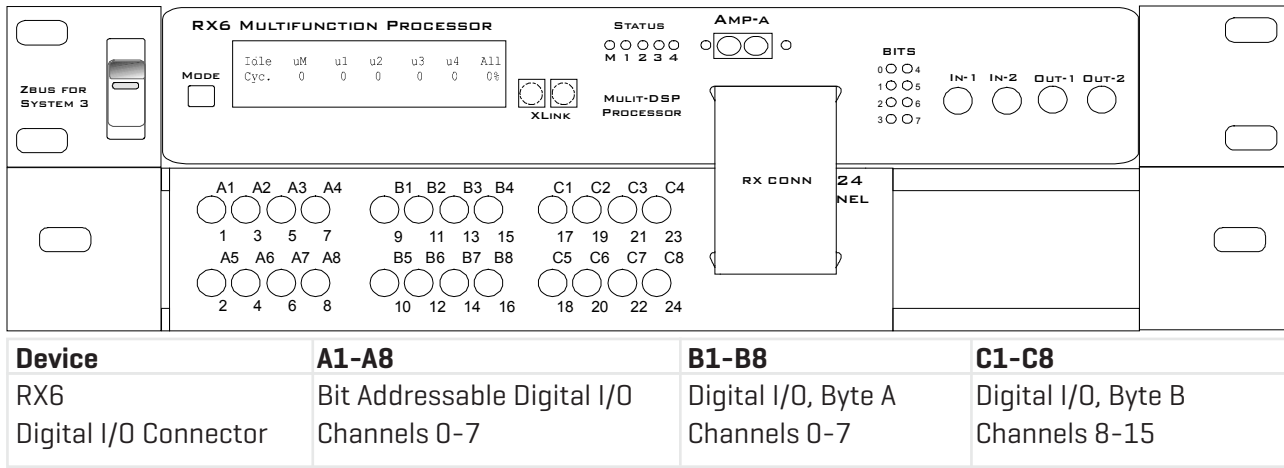

Optional Fiber Optic Port. The RX6 can be purchased with an optional fiber optic port, which can be used to connect the base station to a preamplifier or head tracker interface via a fiber optic cable. See the *System 3 Manual* for more information on using the RX6 with a preamplifier.

Connecting a Head Tracker Interface



From HTI3 to Optical/Amp Port on the Multifunction Processor

Important! Both ends of the cable are the same but the two sides of the connector are different. See the illustrations below to determine the correct way to make the connection for the Headtracker Interface.

Activity Lights on the HTI3. The Active LED indicates if the HTI3 is connected to a base station. This LED will flash slowly (~1 Hz) if this connection is not properly made.

The Data LED indicates if the HTI3 is receiving data from the motion tracker unit. This LED will also flash slowly (~1 Hz) if the tracker is not properly connected to the HTI3.

The Ch1 Stat and Ch2 Stat LEDs indicate if the interface is receiving data from receiver 1, receiver 2 or both.